

DRAWERS PACK

ASSEMBLY & INSTALLATION GUIDE

This information sheet provides details of how to assemble and install sliding drawers for use with storage units.

Please take time to read it through fully prior to starting on the assembly of your sliding drawers.

Tools required (not supplied)

- Crosshead screwdriver

This pack contains:

- **2 x drawer bases** (l)385mm x (w)330mm x (d)8mm
- **4 x drawer sides** (l)400 x (h)125mm x (d)16mm
- **2 x drawer backs** (w)320 x (h)110mm x (d)16mm
- **2 x drawer fronts** (w)395 x (h)173mm x (d)18mm
- **4 x drawer runner assemblies**
- **2 x drawer handles**
- **Fixings** - 4 x drawer front brackets and 8 x screws; 4 x handle screws; 16 x drawer base screws; 8 x drawer back screws; 8 x drawer runner screws

1. Assembling the drawer box

On a flat surface, lay out the pieces to assemble one drawer as shown in illustration a.

Slide the drawer base into the two drawer sides as shown in illustration b and, using a crosshead screwdriver, secure this in place with four screws on each side, through the pre-drilled holes.

Slide the drawer back into place as shown in illustration c and, using a crosshead screwdriver, secure this in place with two screws on each end through the predrilled holes in the metal plates at the rear of each drawer side.

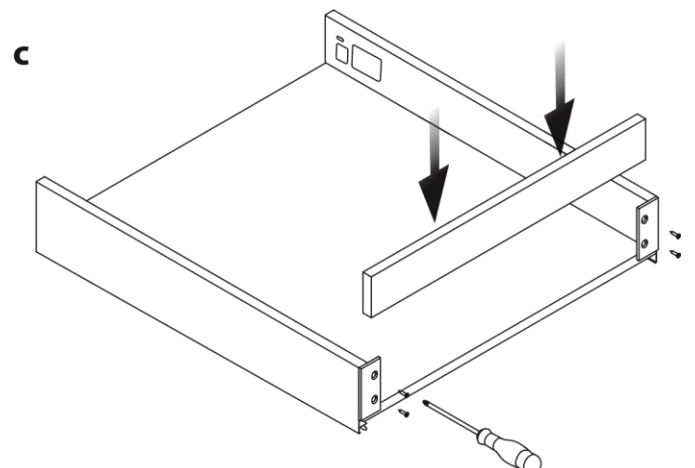
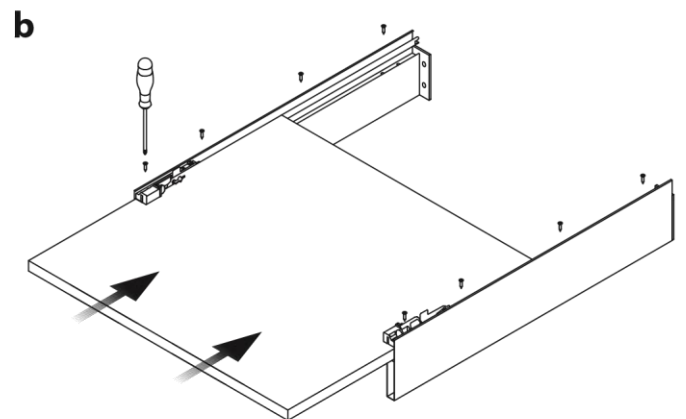
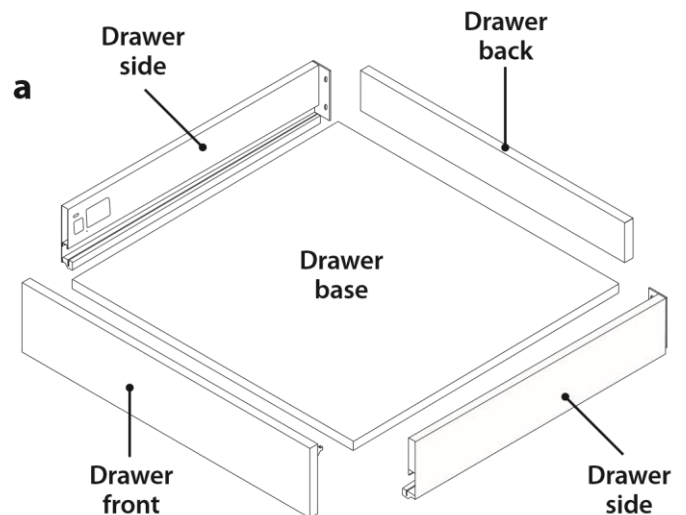

There are two sets of drawer runner mechanisms in this pack. Select one of the sets and separate out the right and left drawer runners. When placed in the positions as shown in illustration **d** match the holes on the side of the runner to the positions of the first two pre-drilled holes on the inside left of your offset shelf stack cabinet – see illustration **e**.

Secure the drawer runner to the side of the cabinet using two of the crosshead screws provided with the offset shelf stack pack – see illustration **f**.

Repeat this process to position the right hand drawer runner to the inside right of the offset shelf stack.

Then, repeat the above two operations to position and secure the second pair of drawer runners in place.

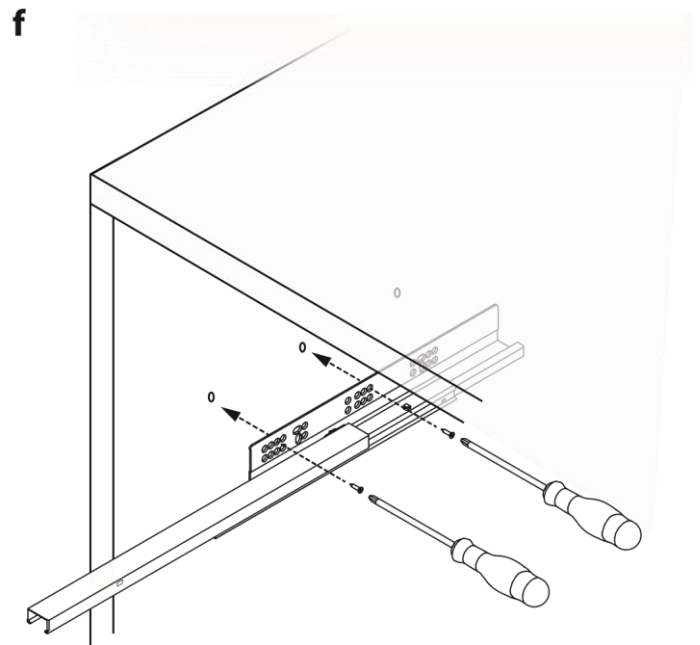
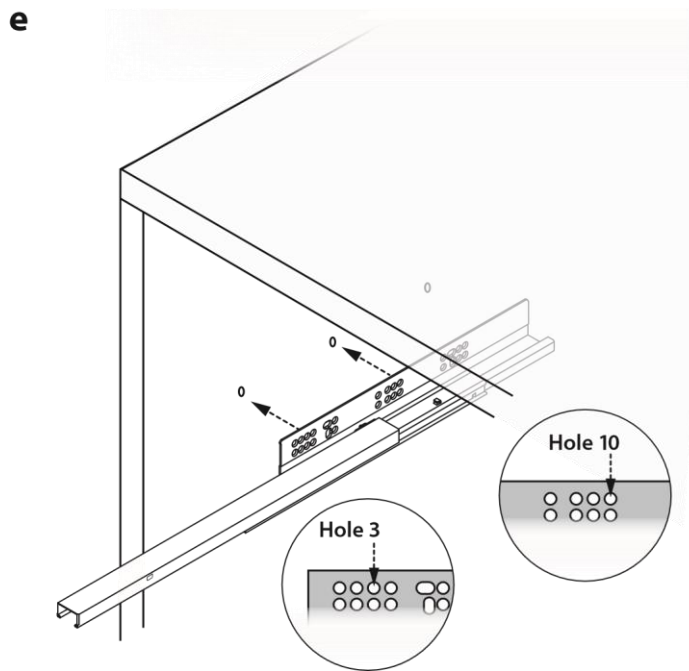
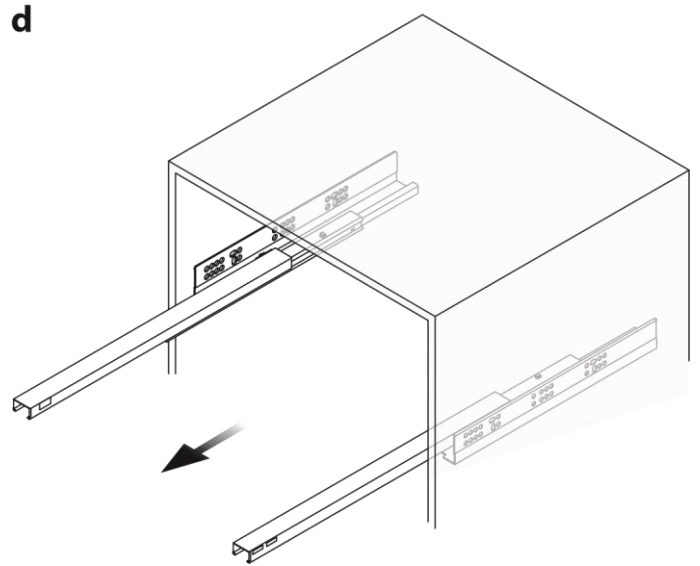

3. Fitting the drawer box

With the runners fully extended, tilt the drawer at slight angle and slide it onto the runners - see illustration **g**. Push it all the way into the back of the cabinet on the runners until you hear a click - see illustration **h**. The drawer should now be attached to the runners and should slide in and out freely.

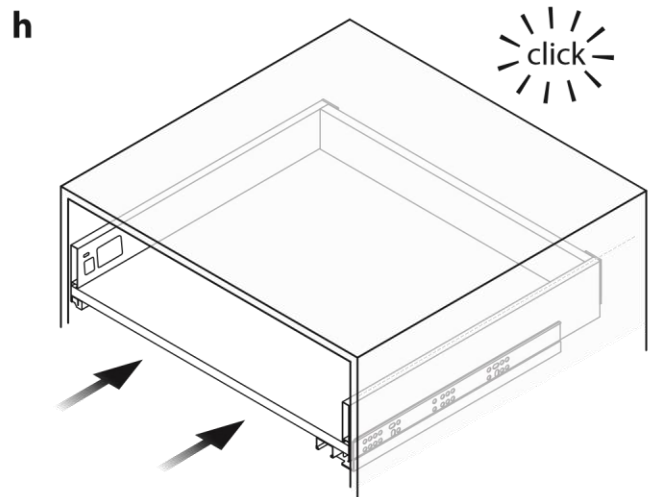
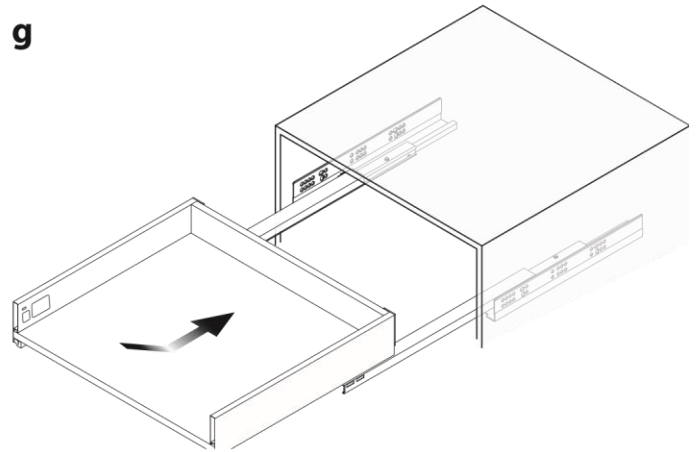

4. Fitting the drawer front

With a crosshead screwdriver and using four of the screws provided, attach the two brackets into the pre-drilled holes on the inside face of the drawer front – see illustration **i**.

Offer up the inside face of the drawer front to the drawer box, ensuring the brackets locate in the recesses in the drawer sides, and push firmly to secure. A click will be heard when the drawer front is in place.

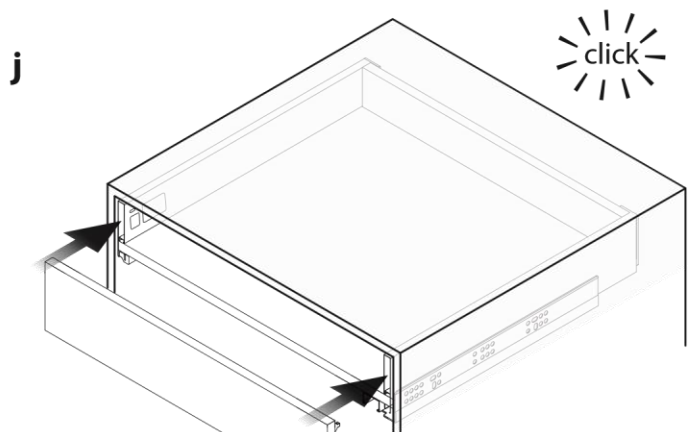
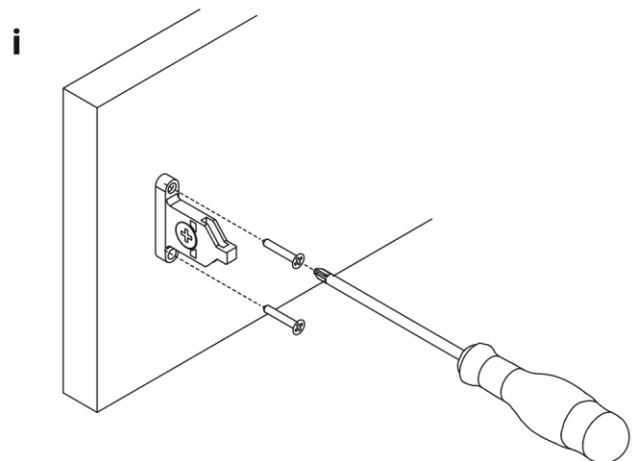

Fix the drawer handle by matching up the countersunk holes in the handle with the two small pre-dilled pilot holes on the top inside edge of the drawer front and using a cross head screwdriver secure with two of the 12mm countersunk screws provided – see illustration k.

Repeat the steps 1 to 5 above to assemble and fit the second drawer.

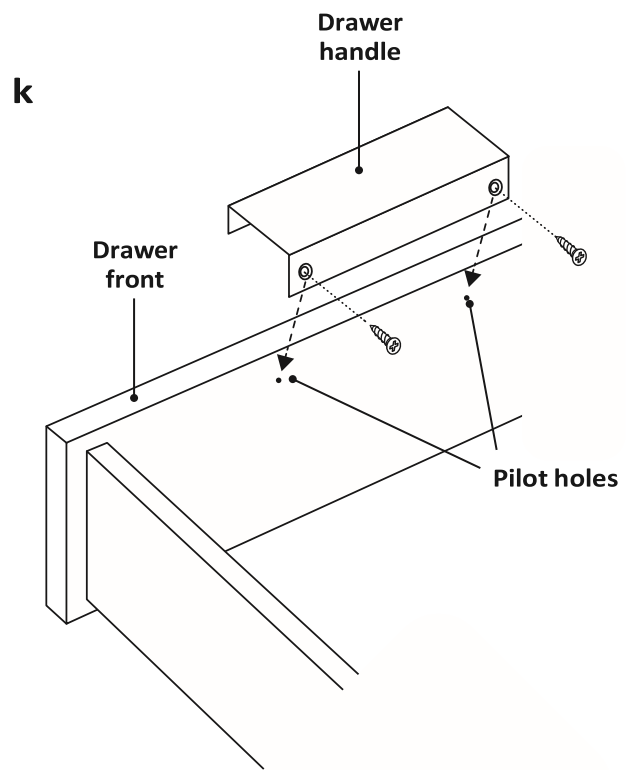

6. Drawer adjustment

The adjustment mechanisms for the drawer can be found on each drawer side just inside the front of the drawer.

To move the drawer to the left or to the right: Turn the screw shown in illustration l clockwise or anticlockwise.

To move the drawer up or down:

Turn the screw shown in illustration m clockwise or anticlockwise.

To lock the drawer box to the runners:

Turn the screw shown in illustration n clockwise. (If for any reason you wish to release the drawer box from the runners, turn the screw anti-clockwise).

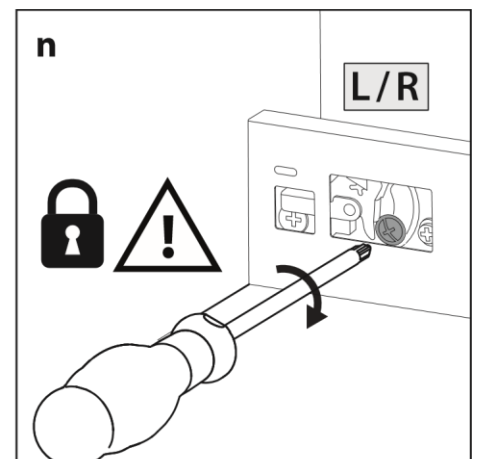
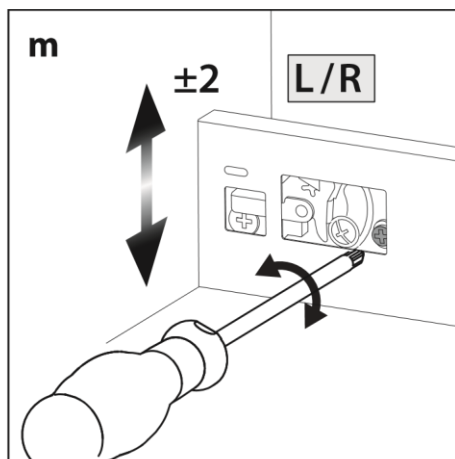
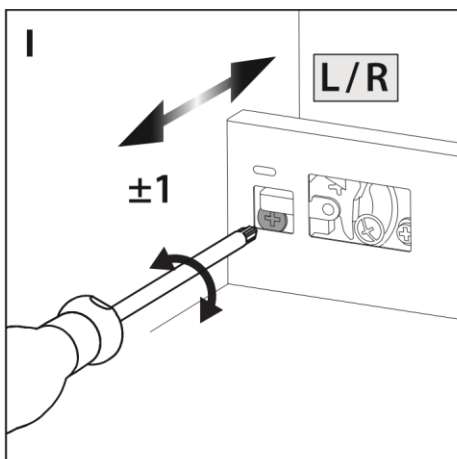



Disclaimer: It is the responsibility of the customer to ascertain that the area for installation is structurally sound and that any drilling necessary will not compromise electrical wiring, water pipes or gas services. The information provided herein is intended as a guide to good practice. The manufacturer cannot be held responsible or liable for any damage, wear or malfunction caused to components due to inadequate or improper installation.

Drawers Pack /Iss 1/Jan 21