

Panelux Interior Kit

HIGH LEVEL SHELF WITH HANGING RAIL & CENTRE SUPPORT POLE

INSTALLATION GUIDE

This information sheet provides details of how to install an internal high level shelf with hanging rail and centre support pole. **Please take time to read it through fully prior to the installation of your sliding wardrobe doors.**

This pack contains:

- **Shelf**
(l)1600/2000/2400mm x (w)450mm x (d)18mm
- **2 x side shelf bearers**
(l)430mm x (w)87mm x (d)18mm
- **1 x back shelf bearer**
(l)1600/2000/2400mm x (w)87mm x (d)18mm
- **Hanging rail**
(l)1600/2000/2400mm
- **Support pole**
(l)1750mm (including fixing brackets)
- **Fixings** - 10 x wallplugs; 10 x 40mm screws; 8 x 30mm screws; 2 x hanging rail brackets; 8 x 15mm screws; self-adhesive screw head cover caps
- **Drilling template**

1. Measuring and cutting to size

Measure the width of the space you require the shelf and hanging rail to span. If this is less than the length of the shelf supplied, cut the shelf and longest shelf bearer down to the length required.

TIP When cutting the shelf and shelf bearer to length use masking tape along the cut lines to prevent the laminate surface from chipping. Carefully remove the tape after you have finished cutting.

2. Fixing the shelf bearers and shelf

The shelf should be positioned so that its underside is at a height of **1750mm** above the floor of the wardrobe. Using a spirit level, draw a pencil line on the back and side walls at this height to indicate where the **underside** of the shelf will sit.

On each of the shelf bearers, mark the position for drilling pilot holes for fixing the bearers to the back and side walls of the wardrobe – see the diagram on page 2. We advise that the pilot holes are countersunk so once

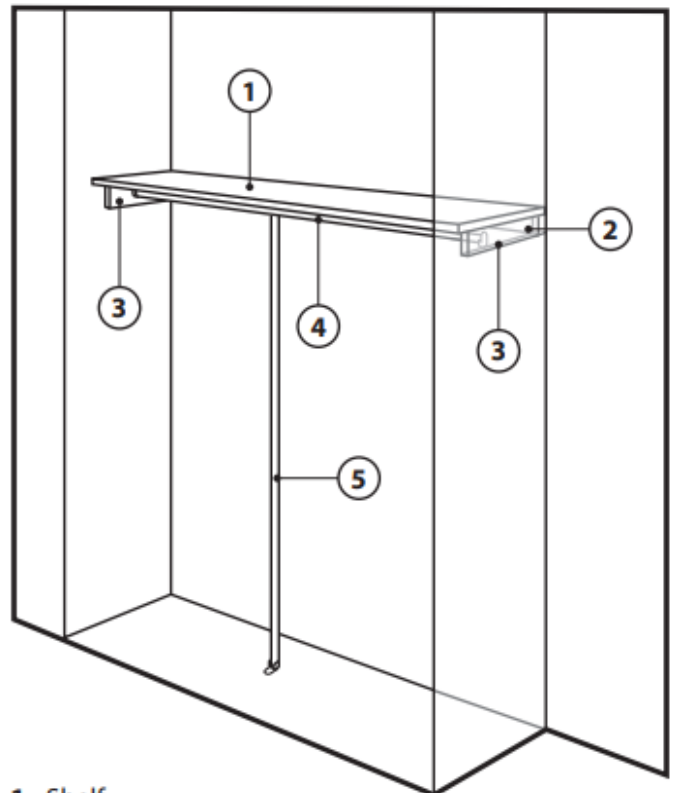

- 1 - Shelf
- 2 - Back shelf bearer
- 3 - Side shelf bearers
- 4 - Hanging rail
- 5 - Support pole

Tools required (not supplied)

- Electric drill, 2mm diam. wood drill bit and 6mm diam. masonry drill bit
- Crosshead screwdriver
- Handsaw (with appropriate blade for cutting MFC)
- Hacksaw (32tpi blade recommended)
- Spirit level
- Bradawl
- Tape measure
- Pencil

in place self adhesive cover caps will fit neatly over the screw heads.

Position the longest bearer against the back wall with its top edge level with the pencil line you have already marked. Using a bradawl through the pilot holes, mark the back wall with the positions for drilling the holes for the wallplugs. Remove the bearer and drill the holes in the back wall using a 6mm masonry drill bit. Push the wallplugs firmly into the holes, offer up the shelf bearer again and secure it in place using the 40mm screws. Repeat this process to fix the two side shelf bearers in place.

Slide the shelf into position and ensure that it is sitting firmly on all three shelf bearers. After the centre support pole has been positioned and fixed in place (see **4. Fixing the centre support pole**), we recommend that, for additional security, the shelf is screwed to the shelf bearers. This can be done from the top side of the shelf using the 30mm screws provided. We recommend drilling and counter-sinking pilot holes for these screws to achieve a neat finished appearance.

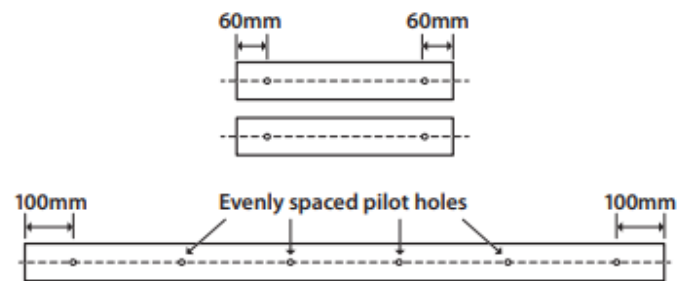

Drill pilot holes through the shelf bearers from each end at the distances shown. Depending upon its overall length, evenly space two or four additional pilot holes along the length of the back shelf bearer, after it has been cut to the required length.

3. Fixing the hanging rail

To ensure the hanging rail is positioned correctly, use the paper drilling template supplied. See the **diagrams 1 and 2** opposite to help you position the drilling template correctly for each side of the hanging rail.

TIP You may wish to mark the positions for the pilot holes on the left hand and right hand shelf bearers with a bradawl, remove the template and then drill the holes; rather than drilling the pilot holes directly through the paper template.

Once the pilot holes are drilled, place the hanging rail brackets in position (ensuring the U-shaped cup is at the bottom) and screw each one in place through the top and bottom holes, using the 15mm screws provided.

Measure the distance between the inside edges of each of the hanging rail brackets and cut the rail to the same length. The hanging rail can then be placed in position and should sit securely in the U-shaped cups of the brackets.

1. Drilling template position for the right hand side hanging rail bracket

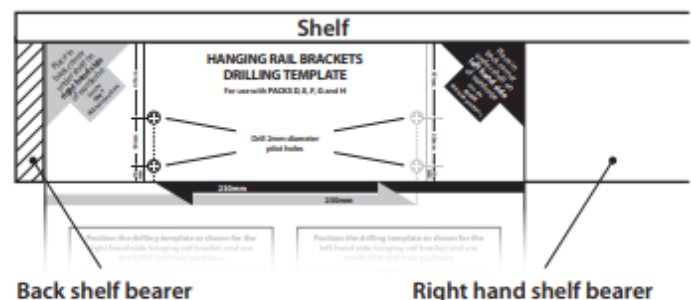

2. Drilling template position for the left hand side hanging rail bracket

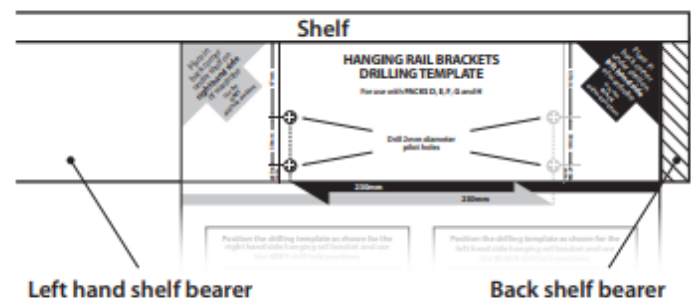

4. Fixing the centre support pole

The support pole should be positioned centrally under the shelf. To ensure the pilot hole for the top support pole bracket is positioned correctly, use the paper drilling template supplied – see **diagram 3** to help you.

TIP For the top bracket, on the underside of the shelf, you may wish to mark the position for the pilot hole first with a bradawl, remove the template and then drill the hole; rather than drilling the pilot hole directly through the paper template.

When drilling the pilot hole take care not to drill completely through the shelf.

Once the pilot hole is drilled, place the support pole in position, ensuring the U-shaped cup on the top bracket is facing the front of the wardrobe (this will mean that the U-shaped cup on the bottom bracket is facing the back of the wardrobe) and secure in place through the available hole in the bracket, using a 15mm screw.

Using a spirit level, ensure that the pole is positioned vertically when viewed from the front and from the side. Drill a 2mm pilot hole through the hole in the bottom bracket into the floor of the wardrobe and then secure the bottom bracket in place using another 15mm screw.

Finally, as described above in (2), secure the shelf to the shelf bearers using the 30mm screws provided.

3. Drilling template position for support pole bracket on underside of shelf

